

Instructions For PT 2200-72A (3823373) and PT 2205-25A (3823374) Cutter Plate Assembly (Adjustable Cutter Bit)

APPLICATION: All Cummins NH/NT engines

USED WITH: PT 2200-72A used with PT 2250-A(3823326) Counterbore Ledge Cutting Tool.
PT 2205-25A used with PT 2205 (3823327) Counterbore Ledge Cutting Tool.

FEATURES: PT 2205-25A and PT 2200-72A have a tapered locating surface and an adjustable cutter bit. It is designed to locate into the lower bore of the engine block counterbore area. The cutter bit can be adjusted to contact the counterbore wall, thus providing 100% cutting of the liner seal ring seat area.

REPLACEMENT: PT 2200-72A can be used in place of the following counterbore ledge cutter plates. "One" cutter plate for all of the various cylinder liners available for Cummins NH/NT 855 engine.
Kent-Moore: PT 2200-22, PT 2200-48 and PT 2200-64. Cummins: 3822956 and 3823375

PT 2205-25A can be used in place of the following counterbore ledge cutter plates. "One" cutter plate for all of the various cylinder liners available for Cummins NH/NT 855 engines.
Kent-Moore: PT 2205-9; PT 2205-11 and PT 2205-18. Cummins: 3823374

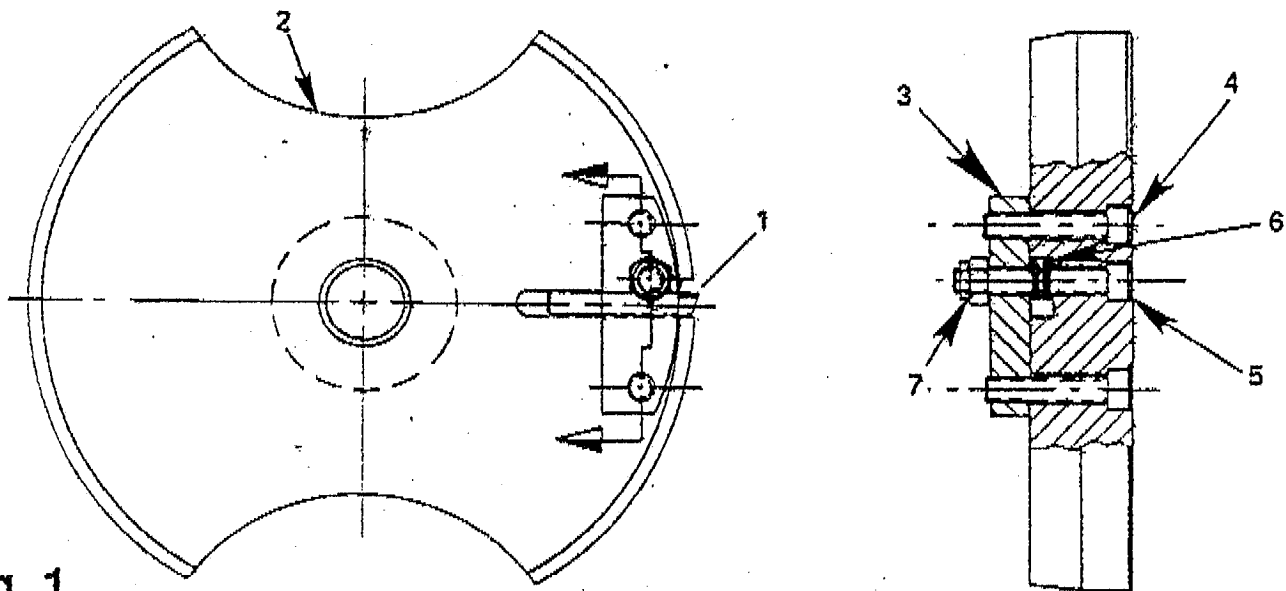

Fig. 1

| ITEM | KENT-MOORE | DESCRIPTION | QTY. | CUMMINS |
|------|--------------------|-----------------------------|------|------------|
| 1 | PT 2200-6 | Cutter Bit | 1 | ST 1255-10 |
| 2 | PT 2200-73 | Cutter Plate (PT 2200-72A) | 1 | |
| | PT 2205-26 | Cutter Plate (PT 2205-25A) | 1 | |
| 3 | PT 2200-74 | Retainer Plate | 1 | 3823375 |
| 4 | RS 9101-600 | Hold Down Capscrew | 2 | |
| 5 | PT 2200-87 | Adjuster Bolt (PT 2200-72A) | 1 | |
| | PT 2205-31 | Adjuster Bolt (PT 2205-25A) | 1 | |
| 6 | RS 30000-15 | O-Ring .156 x .281 x .063 | 2 | 3823376 |
| 7 | Special Order Only | Locknut | 1 | 3823377 |

STEP 1**PREPARE BLOCK**

- A. Remove the cylinder head, piston, and liner of the cylinder to have the counterbore ledge machined. This procedure can be performed either in or out of the chassis. If in chassis, cover the crank shaft and any oil hole gallery to prevent machining chips from entering.
- B. Make sure the top deck of the block is clean and free of burrs. Use a finish mill file (PT 2000-400 or equivalent) and fibrous abrasive pad (PT 2901 or equivalent).
- C. Measure and record the ledge depth in four places 90° apart. (PT 5025 or equivalent).

Mark the shallowest point.

Subtract the lowest number from the highest number. This is the minimum amount to be machined for clean-up.

STEP 2**SET THE CUTTER**

Loosen the two cutter bit hold down cap screws. Install the tool bit into cutter plate by turning the cutter bit adjuster ball counterclockwise. (See Fig.1) Cutter bit face must be facing towards a clockwise rotation cut.

NOTE: The point of cutter should not extend beyond the outer diameter of the cutter plate. If the cutter bit does stick out, damage to the tool bit will occur when locating the counterbore tool onto engine block.

Do not tighten cutter bit hold down cap screws at this time.

IMPORTANT: Hold down cap screws MUST BE loose when ever adjustment is being made to cutter bit, in or out movement.

Fig. 2

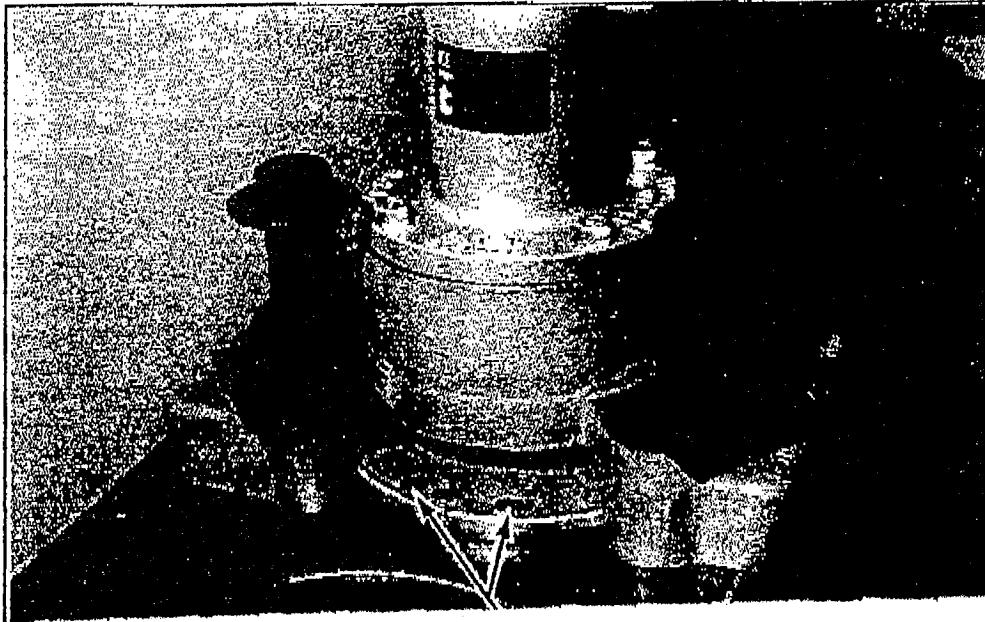

Fig. 3



STEP 5

CHECK TOOL LOCATION

Lift the T-Handle slightly and rotate main shaft clockwise to ensure cutter plate turns freely without binding up. If necessary, loosen cap screws and reposition the tool (Per Step 4).

STEP 6

ADJUST CUTTER BIT

Using the counterbore tool handle, raise the cutter plate from the counterbore seat by approximately 1/2" (See Fig. 3). Turn bottom lock collar until it contacts housing, thus holding cutter plate in this position.

Use Hex Key Wrench to turn the tool bit adjusting bolt clockwise until tool bit contacts liner bore wall. Then tighten the two hold down cap screws to secure the tool bit. (See Fig. 4)

Rotate the main shaft clockwise to ensure cutter plate turns freely without binding up or scraping the counterbore wall. If necessary, loosen the two hold down cap screws and reposition the tool bit against the counterbore wall. Retighten screws.

Fig. 4



Cutter Bit Adjusting Bolt

STEP 7**ZERO OUT THE DEPTH SET COLLARS**

Back off lower bottom lock collar and carefully lower the cutter plate into the bore and allow the cutter to reset on the counterbore ledge. Rotate both depth set collars down until the bottom collar contacts the main housing. Do not force collar beyond this point, as it will lift the cutter plate and prevent an accurate zero reading.

STEP 8**SETTING THE DEPTH OF CUT**

Determine the final depth of cut and back off the top depth set collar accordingly. Each graduation on the depth set collar increases the depth of cut by one thousandth (.001"). Tighten the thumb screw on the top collar securely.

STEP 9**CUTTING THE COUNTERBORE**

Fill oil pit on the tool's main housing with 30W nondetergent oil to maintain lubrication during use. Back off the bottom depth set collar two graduations (or less) and tighten the thumb screw securely. Cut the counterbore by turning the T-Handle clockwise and maintaining constant downward pressure on the tool. Do not stop in the same handle position. Alternate where stopping to avoid creating a ridge in the counterbore. Continue backing off the lower depth set collar (no more than two graduations per cut) and checking depth measurements between each adjustment. Plan to take a one thousandths (.001") final cut to meet the final predetermined counterbore depth. This ensures a very fine machined finish will be obtained.

STEP 10**TOOL REMOVAL**

Loosen the two cutter bit hold-down cap screws and rotate cutter bit adjusting screw counterclockwise until cutter bit is retracted into cutter plate. Remove four machine hold down bolts.

Available Accessory:

PT 2200-83 Spacer Block

Application: All Taper Cutter Plates
Used with PT 2250-A, PT 2205 & PT 2210
Counterbore tools.

This spacer block saves you time by eliminating the need to rest depth of cut when machining two or more counter bore ledges.

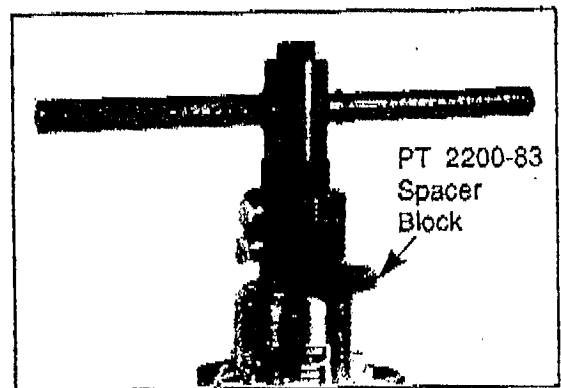
**SPX***Exponent of Excellence***KENT-MOORE**

*Kent-Moore
Heavy Duty Division
SPX Corporation*

29784 Little Mack
Roseville, MI 48066-2298

1-800-328-6657 (USA, Canada)
Telex 244040 KMTR UR
Fax 313-774-9870

PT 2200-82A